

Institute of Software, Chinese Academy of Sciences



xMath
The xMath library has promoted various important applications on Sunway

With high influence in China's high-performance computing (HPC), this research group has been devoting to the R&D of software for domestic supercomputers such as Sugon, Lenovo, Sunway and Tianhe during the past two decades. To tackle with the major challenges of HPC, they developed a new generation of high-performance algorithm library on Sunway TaihuLight, and successfully promoted a number of important applications in China. The group also designed a series of novel domain-decomposition algorithms for large-scale heterogeneous environments, and managed to make Tianhe-2 the world's No. 1 place in the HPCG List. Particularly in 2016, because of the major breakthroughs they made in the design of 10-million-core scalable fully implicit solvers, the group won the ACM Gordon Bell Prize, which is the first time that China has won this high honor in its 29-year history. This achievement is seen as not only a landmark breakthrough in China's HPC development but also an irreplaceable contribution to world's recognition of China's global leadership in HPC.

Outstanding contributors of this research group

Yang Chao

10-million-core scalable fully implicit algorithm and led the R&D of the new

Sun Jiachang

As a founder and pioneer of parallel computing in China, he has made great contributions to the development of high-performance software, the cultivation of students and talents, and the combination of mathematics, computers and

2016



xMath 2014 11 2 HPCG
User's manual for the new generation high-performance

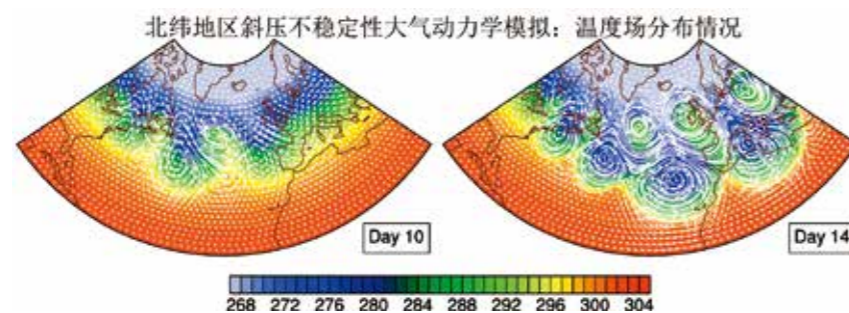

The 10m-core scalable fully implicit solver can substantially improve the simulation



2016 11 17 SC
2016

国产P/E级高性能软件与算法库研究集体

研究集体主要科技贡献:

研究集体突出贡献者

Yang Chao

Sun Jiachang 研究集体主要完成者

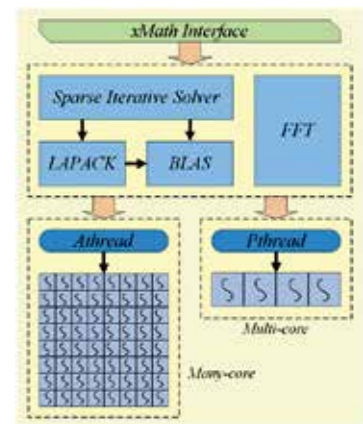

xMath
SW26010
The xMath library fully supports the domestic SW26010 many-core processor,

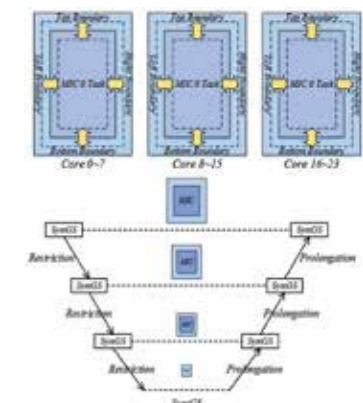

Schematic of the heterogeneous domain